

**BIORETENTION TRENCH**  
NOT TO SCALE

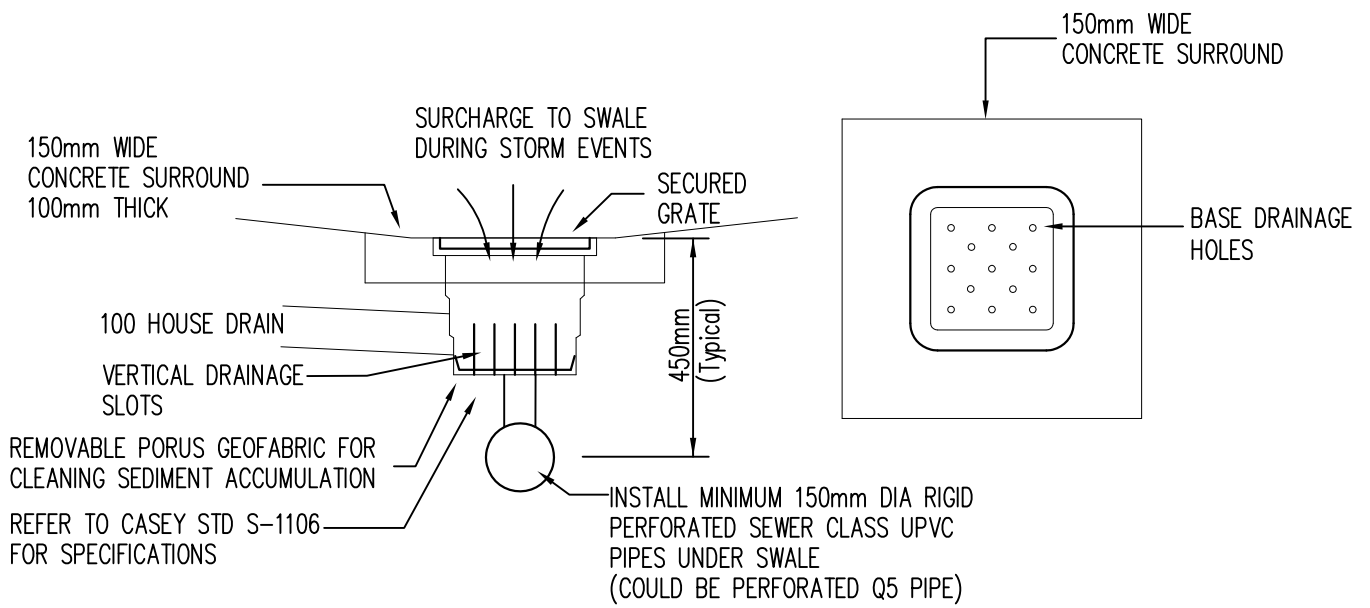

**DETAILS OF SURCHARGE TO PIT TO SWALES AND BIORETENTION SYSTEMS**  
NOT TO SCALE

NOTE:  
1. REFER TO CASEY STD S-1106 FOR FILTER MATERIAL SPECIFICATION

**CITY OF CASEY**

BIORETENTION TRENCH  
STANDARD ELEMENTS

MANAGER OF ENGINEERING &  
ENVIRONMENTAL SERVICES

LAST UPDATE 09.11.2012

S-1107

AMENDMENTS: